



a participated compay by: DEMEDE and Trabajos Técnicos y Científicos s.l.

GREEN FISH

1. Background

Fisheries are fishermen associations dedicated to extractive fishing, fish processing and distribution. Energy consumption to maintain the fish cod for storage and distribution is a relevant part of their cost structure.

Usually, most of the electrical energy consumed is dedicated to the production of cold in different states, as ice making, low temperature for maintenance of cold storage and cooling for air-conditioning. Customarily, fresh water is used for ice making.

Fisheries are located in coastal or island areas and they have to rely on electricity and fresh water for their production process. Lack of one or both is quite common.

The carbon print associated to storage and distribution can be reduced if renewable sources are used to produce electricity instead of fossil fuels.

The present project has been partially financed by InvestinSpain (Ministry of Economy and Competitiveness of Spain) and carry on in collaboration with Fuerteventura Biosphere reserve.

2. Specific Objectives

The aim of this project is to demonstrate the feasibility of a sustainable zero emission, cooling and ice production for local fisherman at Fuerteventura Biosphere Reserve.

The project uses a well known set of technologies: absorption chiller, solar thermal and photovoltaic and wind energy, to green the fisheries business: improving performance while diminishing the environmental impacts. Also, improving water efficiency innovating in the production of ice from sea water instead of fresh water, which is crucial in arid areas such as Fuerteventura.

3. Description of the technical solution

Nowadays, mechanical compression is the most common cooling cycle. As working fluids, it uses R404A and volumetric electrical power compressors. The evaporators are used to produce ice in chips or to keep the storage cooled.

Instead, absorption refrigeration technology is used. Absorption technology is the oldest cold production technology. It is based on the replacement of the usual electric compressor with a thermo-chemical compressor that uses medium-low temperature heat, so waste heat or solar energy may be used.

4. Technical description

Two centuries ago, the absorption chiller was developed by Von Linde targeting to liquefy air. At those days, it was not possible to compress gases mechanically, thus, the thermo-chemical compressor was developed. It uses heat to produce the increase of pressure of the refrigerant that has previously been dissolved in an absorbing solution.

Mechanical compression replaced absorption compression when it became available due to its simplicity until recent times when energy efficiency and environment has become a major decision factor.

Absorption machines commonly are used to produce air conditioning, and water is used as the refrigerant with lithium bromide solution as absorbent salt. In order to reach lower temperatures the use of other refrigerants such as ammonia is needed. Ammonia, combined with an absorbent as lithium nitrate, or water, can reach temperatures up to -30°C in the evaporator of the refrigeration machine, required for freezing water and ice production.

The ammonia-water machine is a well developed technology, although their use is not widespread for the following reasons:

- The use of residual heat or solar is not fully developed.
- Efficiency is low.
- It presents technological difficulties as a distillation column to separate the ammonia vapor from water vapor after boiling in the generator is needed.

When compared with the mixture: ammonia-water, the combination of ammonia with a salt, lithium nitrate, has the following advantages:

- Efficiency improvement, verified through: thermodynamic modeling and experiments in test bench.
- Eliminates the need to use a distillation column simplifying the technology.
- Working temperatures are within the range of solar energy.

The current project address to the following innovations:

- Commercial development of an absorption systems using ammonia-lithium nitrate as working fluid
- Combination of thermal solar power with an absorption refrigeration cycle.
- Possible use of sea water to produce ice.

Morro Jable Fisherman Community has been selected as pilot project for "Sustainable Fishery" Installation of and solar thermal field and an absorption chiller for ice production which uses sea water.

This location is ideal for a first implementation of the product for the following reasons:

- Excellent conditions of sunshine all year round.

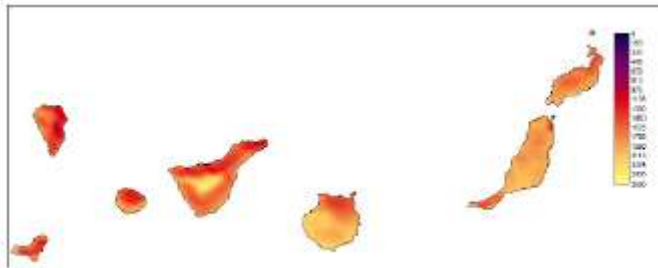

Figure . Canary Islands annual average solar irradiation

- High price of electricity and fossil fuels.
- High energy demand. The actual production of ice is between 4 to 8 tons per day depending on the fish capture.
- Cold generation equipment currently active in the guild at the end of its useful life, low efficiency.
- 482 m² flat roof exposed to the unobstructed south and without shadows.
- The fishery is at short distance from the Natural Park of Jandia thus reducing the ecological impact of economic activities in this area in accordance with the environmental objectives of the Fuerteventura Government - Biosphere Reserve.



Figure . Satellite image of Morro Jable Fishery at Fuerteventura Island



Figure . Image of surroundings of Morro Jable Port, and Fishery (in yellow)

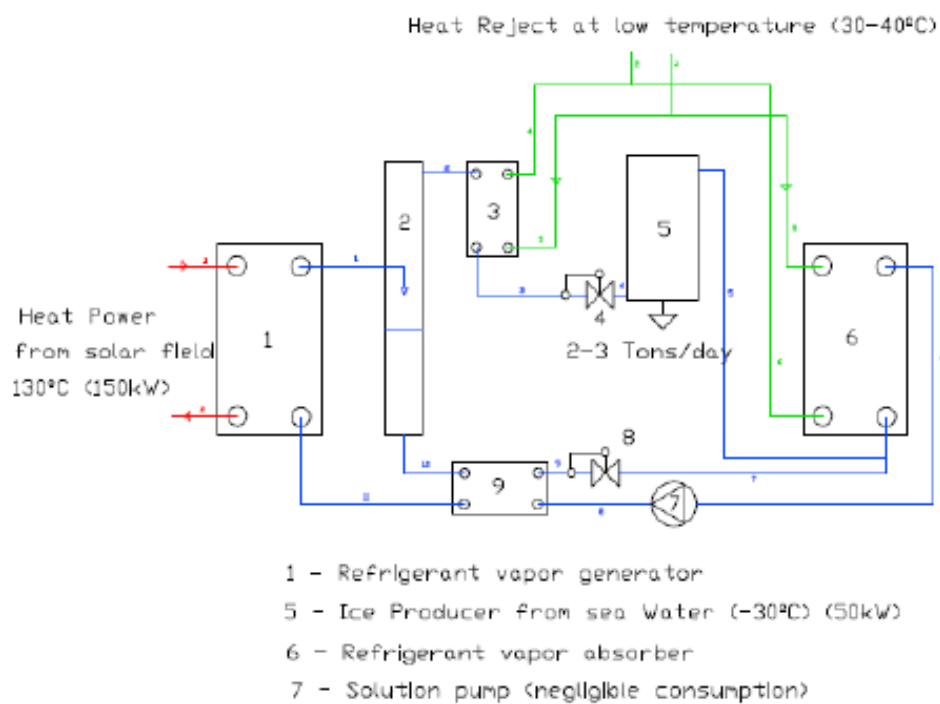

Figure . Flowchart of the system



Figure . Image of the installation



Figure 6 . Image of the absorption machine for thermo-chemical NH₃ vapor compression.



Figure 7 . Image of the flake ice maker (evaporator of the absorption refrigeration system)



Figure 8 . Image of the complete installation. Live view at www.demede.es/investigacion.html

